

TITLE: Packaging Instructions for GERBER EDGE® LE - Serial Numbers 492xxx through 495xxx and AOLxxxxxxx

Category: Printing/Imaging – Gerber EDGE – Service/Support

Gerber FastFact #: 2012

Supplied by: Technical Hardware Support

Last Modified: 2/21/03

Summary: This document provides the needed instructions to pack the Gerber EDGE LE for return. This only to Serial Number 492xxx through 495xxx and AOLxxxxxxx.

Underlined text indicates change from the previous document.

Unpacking and Repacking to Prevent Damage

The Gerber thermal printer is shipped in specially-designed packaging materials to prevent damage while in transit. Save these packaging materials for future use in case you need to ship the printer.

Packaging concept

The chassis and covers must be protected from damage that can occur from dropping or rough handling. The packaging materials shown below on the left are designed to protect the machine during transit.

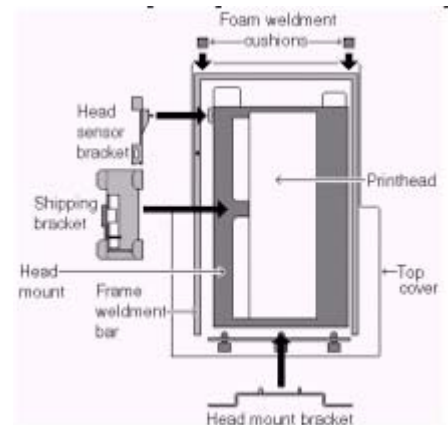
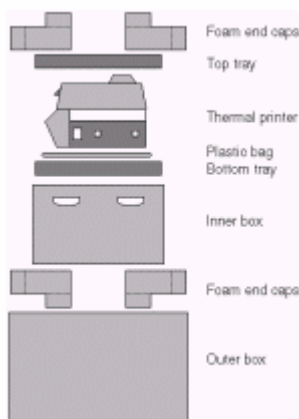

In addition, it is critical to prevent movement of the head mount and printhead during shipment. The illustration on the right shows the location of the brackets and foam cushions which protect the areas inside the top cover.

CAUTION: Failure to repackage the printer with the specified packaging materials may result in damage to the unit. Always repack the printer as described in this bulletin. Gerber is not liable for shipping damage due to improperly packed units. If you do not have the proper packaging materials, call the Gerber Field Service Department at 800-828-5406.

Unpacking the thermal printer

Unpacking the printer is a three-step process:

1. Removing the printer from the boxes
2. Removing the brackets and foam cushions in the printer cover
3. Preparing the printer for use

Refer to the illustrations at the beginning of this section to identify and locate the packaging materials, brackets, and foam cushions.

Removing the printer from the boxes

WARNING: Two persons are required to lift or move the printer. It weighs approximately 90 pounds (40.8 kilograms) packaged for shipment and 76 pounds (34.5 kilograms) unpacked.

1. Open the top of the outer box and lift out the top two gray foam end caps.
2. Remove the inner box and open the top.
3. Remove the power cord, data cable, and packaged accessory kit from the top tray of the inner box, then remove the top tray.
4. Lift the printer out of the box and remove the plastic bag it is wrapped in.

Removing the brackets and cushions in the printer cover

CAUTION: Remove all packaging before power-up to prevent damaging the printer.

1. Push the cover latch in, raise the cover, and remove the two black foam weldment cushions in the corners of the top cover. Save the cushions.
2. Push the three cartridge pins down and remove the head mount bracket as follows:

- Carefully push on the top part of the printhead so that the printhead assembly pivots to the rear inside the cover. Do not push on or touch the printhead element itself.
- Disengage the right pin of the bracket from the bottom of the printhead assembly by pushing down on the center of the bracket while rotating the bracket clockwise.
- Disengage the left pin from the bottom of the printhead assembly.

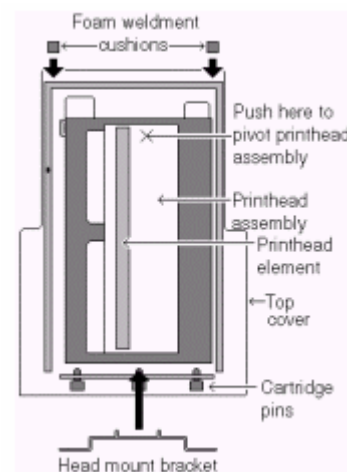

- Save the head mount bracket.
3. Remove the shipping bracket as follows:
- Loosen the eight nuts on the shipping bracket assembly with the wrench provided in the accessory kit.
 - Push down on the front and rear slide tabs to unclamp the slides from the frame weldment bar and head mount.
 - Slide the studs out of the notches and remove the shipping bracket from the frame weldment bar and head mount.
 - Save the shipping bracket.

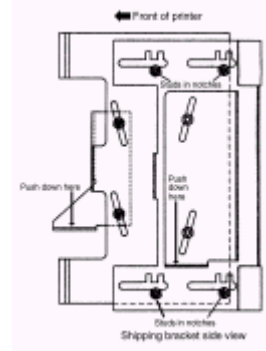

4. Remove the head sensor bracket as follows:
- Remove the nut attaching the bracket to the cartridge support bracket using the wrench provided in the accessory kit.
 - Remove the hex screw and washer attaching the bracket to the frame weldment bar using the wrench provided in the accessory kit.
 - Disengage the stud from the cartridge support bracket, then slide the bracket up the frame weldment bar and rotate the bracket off the bar.
 - Save the head sensor bracket and hardware.

Preparing the printer for use

1. Locate the two black plastic power cord clips in the packaged accessory kit and push them into the two holes in the right side panel.
2. Remove the label from the power entry module and plug the power cord into the module.
3. Attach the power cord to the right side panel and into the power cord clips.
4. Refer to the printer owner's guide to attach the data cable, then connect the printer to your computer system.

Repacking the printer for shipment

Repacking the printer is a three-step process:

1. Disconnecting the printer
2. Installing the brackets and foam cushions in the printer cover
3. Packing the printer in the boxes

Disconnecting the printer

1. Turn on the printer to automatically set the head mount to the correct position.
2. Turn off the printer.
3. Disconnect the power cord and data cable.
4. Remove the black plastic power cord clips.

Installing the brackets and foam cushions in the printer cover

Each piece of packaging inside the printer cover has a specific function. Understanding the functions will help you successfully install the packaging and prevent damage to the printer.

- The head sensor bracket prevents the head mount from moving forward into the head up/down sensor assembly.
- The shipping bracket assembly prevents the head mount from moving up into the cover. The nuts on the bracket must be very tight so that the parts of the bracket do not slip apart.
- The head mount bracket protects the platen, printhead, and head mount fans.
- The black foam weldment cushions prevent the frame weldment from moving.

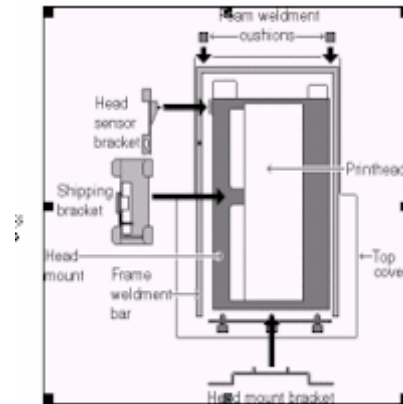

Installing the head sensor bracket

Mount the bracket clip around the frame weldment bar.

Insert the threaded stud into the mounting hole located in the cartridge support bracket.

Attach the bracket to the cartridge support bracket with the M3 nut. Do not tighten the nut at this time.

Attach the bracket to the frame weldment bar with the M4 hex screw and lock washer. Use the wrench to tighten both the M4 screw and the M3 nut.

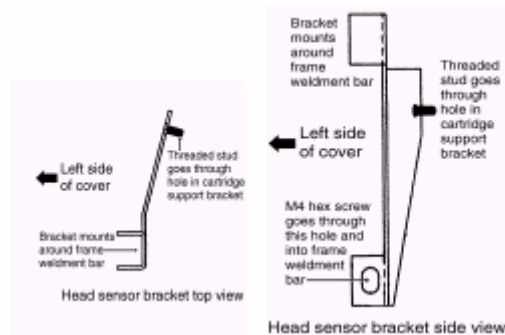

Installing the shipping bracket assembly

Make sure that the eight nuts and star washers are loose on the bracket so that all the parts of the bracket assembly slide smoothly.

Push down the rear slide shown in the illustration below.

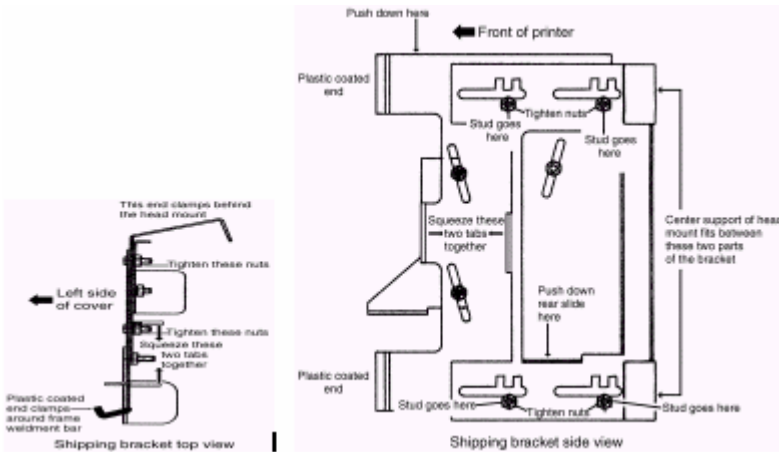

Position the shipping bracket so that the bare metal end is behind the head mount and the plastic coated end is around the frame weldment bar near the static eliminator brush.

Squeeze together by hand the two tabs shown in the illustration until the head mount moves toward you and the four studs can slide into the single notch as indicated in the illustration.

Push down on the plastic coated end as shown in the illustration so that the four studs slide into the notches indicated in the illustration, then tighten the four nuts with the wrench provided.

Push up on the front slide tab to clamp the bracket face shown below against the frame weldment bar, then use the wrench to tighten the two nuts.

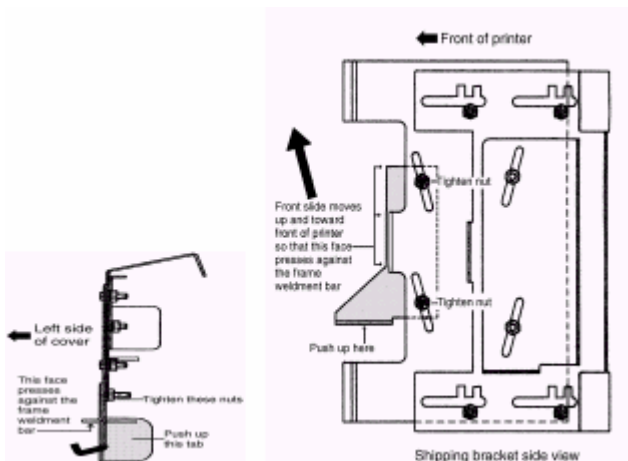

Push up on the rear slide tab to clamp the bracket face shown below against the head mount, then use the wrench to tighten the two nuts.

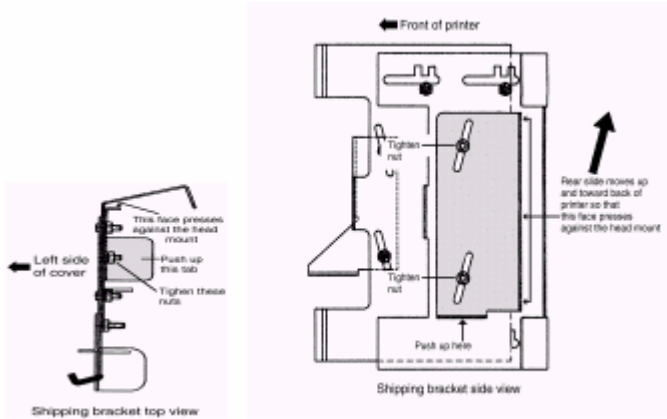

Installing the head mount bracket

1. Lower the three cartridge pins.
2. Carefully push the top part of the printhead as shown at the right so that the printhead assembly pivots to the rear inside of the cover. Do not push or touch the printhead element itself

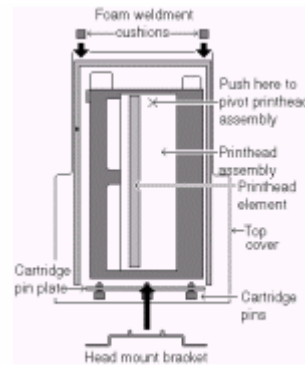
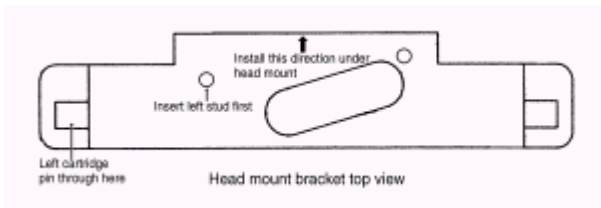

3. Orient the part as shown above.
4. Insert the bracket between the printhead assembly and the cartridge pin plate. The studs go into two holes on the bottom of the printhead assembly. To locate the holes, look at the top of the printhead assembly – the holes are the same on the bottom as on the top. Insert the bracket as follows:
 - Insert the left stud first.
 - Rotate the bracket counterclockwise while pushing down on the center of the bracket until the right stud is inserted.
 - Verify that the part is seated flush against the bottom of the printhead assembly.
5. Release the three cartridge pins so that they protrude through the bracket plate.

Installing the foam weldment cushions

Install the two black foam weldment cushions at the top corners of the cover inside the lip between the latches and the cover.

Packing the printer in the boxes

Lower and latch the cover. Verify that the latch is fully engaged and the cover does not move.

WARNING: Two persons are required to lift or move the printer. It weighs approximately 90 pounds (40.8 kilograms) packaged for shipment and 76 pounds (34.5 kilograms) unpacked.

1. Put the printer into the plastic bag and tape the bag closed.
2. Put the bottom tray into the inner box.

CAUTION: Before performing the next step, look inside the inner box and determine the location of the wide cardboard cushion area of the bottom tray. The keypad end of the printer must be over the wide cushioned area.

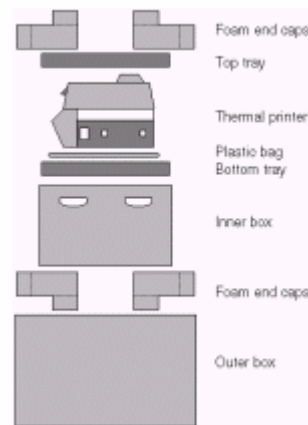

3. Lift the printer into the inner shipping box. Make sure it is seated properly on the bottom tray.
4. Put the top tray on top of the printer with the cutout section around the "top hat" of the cover, then fold the side flaps.
5. Fold down the flaps of the inner shipping box and make certain that the printer does not move inside the box. Tape the box flaps, preferably with fiber reinforced tape.
6. Install the two lower foam cushions in the outer box.
7. Put the inner box on the cushions and make certain that the cushions uniformly support the box.
8. Install the remaining two foam cushions on top of the inner box, then fold down the flaps of the box. Make certain that the printer does not move inside the box. Tape the box flaps, preferably with fiber reinforced tape.