

TITLE: AR600 Model GP5 230V Dial Operated Spindle Controller Programming Guide

Gerber FastFact # 5023

Supplied by: Gerber Service

Last Modified: November 30, 2001

Summary: This document explains how to verify and change the programming parameter values for a AR600 Model GP5 230V Dial Operated Spindle Control.

How to Verify Programming Parameter Values

Warning: Touch the keypad and display area only. Dangerous voltages exist at the upper and lower connector banks, the wire bundle, the fan fuses, and the fan. Coming in contact with any of these areas can result in serious injury or death.

1. Turn power off at the front of the controller
2. Loosen (2) door clamp screws on right side of door. Open door
3. Turn power on by Using an adjustable wrench to rotate on/off switch shaft clockwise 90 degrees
4. Keypad display LCD will light up and flash "CALL"

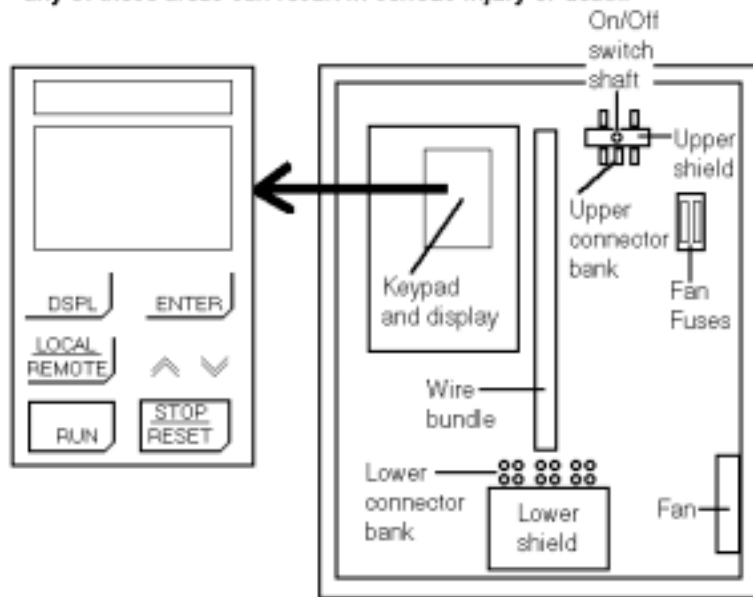

5. Simultaneously press the "Display" and "Enter" keys on the controller keypad. u-01 will be displayed. Simultaneously press the "Display" and "Enter" keys again and n002 will be displayed. n002 is one parameter out of 108.

Note: PRESS THE DISPLAY AND ENTER KEYS SIMULTANEOUSLY

6. To verify the value of parameter n002 press the "Enter" key. Verify the parameter value to the attached parameter value list.
7. Verify the remaining parameters as follows:
 - 7a. Press the "Display" key, (The last parameter will be displayed)
 - 7b. Press "↑" key to view the next parameter
 - 7c. Press "Enter" to view the current value
 - 7d. Repeat steps 1a through 3a for all parameters.

How to *Change* Programming Parameter Values

1. Use the procedure on the previous page to get into the parameters menu
2. Press “display” until n001 parameter is displayed. Press the “Enter” key to view the value In parameter n001
3. Use the “↑” key to change the Parameter value from “0” to “3”
4. Press the “Enter” key to store “3” as the new value. “End” will be displayed when the value is stored
5. Follow steps 5a through 5e to change any parameters that do not match the value on the chart
 - 5a. Press display and use the “↓” or “↑” key to the parameter #
 - 5b. Press the “Enter” key to view the parameter value
 - 5c. Use the “↓” or “↑” key to change the value
 - 5d. Press “Enter” to store new value
 - 5e. Repeat steps 5a through 5d to change any other parameters
6. When changes are complete return to parameter # n001 and change value back to “0” and press “Enter” to store
7. Using an adjustable wrench, turn the on/off switch shaft counterclockwise 90 degrees to turn power off to the unit
8. Close door and secure the two door clamp screws

Programmed Parameter Values

n001	0	n028	0	n055	2.0	n082	0
n002	3	n029	36	n056	0	n083	0.2
n003	230.0	n030	100	n057	0	n084	0
n004	0	n031	25	n058	0.0	n085	1.00
n005	0	n032	16.0	n059	0.0	n086	1.0
n006	1	n033	3	n060	1.0	n087	10.0
n007	1	n034	3	n061	1	n088	0.00
n008	0	n035	0	n062	0	n089	0
n009	1	n036	2	n063	0	n090	100
n010	F	n037	4	n064	30	n091	0.0
n011	230.0	n038	9	n065	1.0	n092	0
n012	400.0	n039	10	n066	0.0	n093	0
n013	230.0	n040	0	n067	0.0	n094	1.0
n014	300.0	n041	1	n068	0.434	n095	0
n015	1.5	n042	0	n069	172	n096	94.75
n016	10.0	n043	1	n070	1	n097	50
n017	1.5	n044	0	n071	170	n098	12
n018	10.0	n045	0	n072	160	n099	1
n019	3.5	n046	100	n073	0.0	n100	0
n020	7.0	n047	0	n074	4	n101	0.5
n021	10.0	n048	0	n075	160	n102	0.2
n022	10.0	n049	1.00	n076	1.0	n103	1
n023	1	n050	6	n077	0.0	n104	1
n024	20	n051	0	n078	0.0	n105	0
n025	360	n052	150	n079	0	n106	0
n026	0	n053	0.7	n080	7	n107	2
n027	0	n054	100	n081	8	n108	1