

## AR600 Model GP5 380/460V Dial Operated Spindle Control

Gerber FastFact # 5025

Supplied by: Gerber Service

Last Modified: November 30, 2001

Summary: This document explains how to verify and change the programming parameter values for a AR600 Model GP5 380/460V Dial Operated Spindle Control.

### How to Verify Programming Parameter Values

**Warning:** Touch the keypad and display area only. Dangerous voltages exist at the upper and lower connector banks, the wire bundle, the fan fuses, and the fan. Coming in contact with any of these areas can result in serious injury or death.

1. Turn power off at the front of the controller
2. Loosen (2) door clamp screws on right side of door. Open door
3. Turn power on by Using an adjustable wrench to rotate on/off switch shaft clockwise 90 degrees
4. Keypad display LCD will light up and flash "CALL"

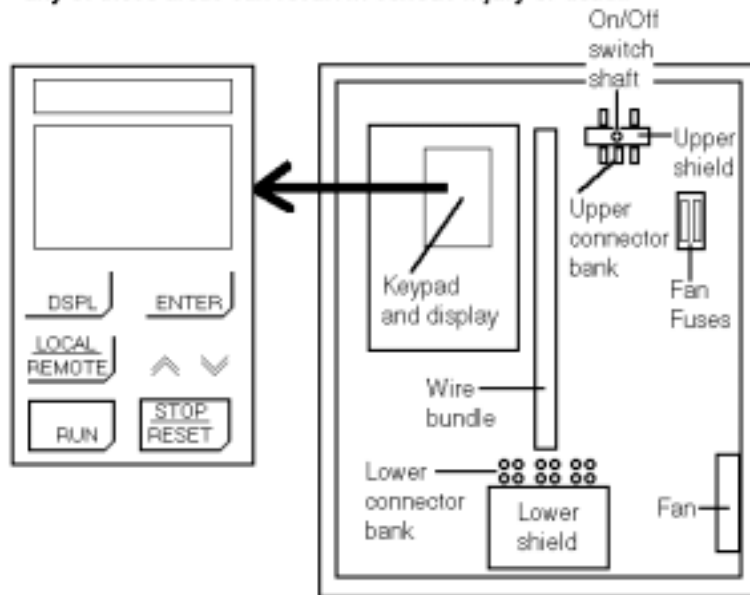

5. Simultaneously press the "Display" and "Enter" keys on the controller keypad. u-01 will be displayed. Simultaneously press the "Display" and "Enter" keys again and n002 will be displayed. n002 is one parameter out of 108.

**Note:** PRESS THE DISPLAY AND ENTER KEYS SIMULTANEOUSLY

6. To verify the value of parameter n002 press the "Enter" key. Verify the parameter value to the attached parameter value list.
7. Verify the remaining parameters as follows:
  - 7a. Press the "Display" key, (The last parameter will be displayed)
  - 7b. Press "↑" key to view the next parameter
  - 7c. Press "Enter" to view the current value
  - 7d. Repeat steps 1a through 3a for all parameters.

---

## **How to *Change* Programming Parameter Values**

1. Use the procedure on the previous page to get into the parameters menu
2. Press “display” until n001 parameter is displayed. Press the “Enter” key to view the value in parameter n001
3. Use the “↑” key to change the Parameter value from “0” to “3”
4. Press the “Enter” key to store “3” as the new value. “End” will be displayed when the value is stored
5. Follow steps 5a through 5e to change any parameters that do not match the value on the chart
  - 5a. Press display and use the “↓” or “↑” key to the parameter #
  - 5b. Press the “Enter” key to view the parameter value
  - 5c. Use the “↓” or “↑” key to change the value
  - 5d. Press “Enter” to store new value
  - 5e. Repeat steps 5a through 5d to change any other parameters
6. When changes are complete return to parameter # n001 and change value back to “0” and press “Enter” to store
7. Using an adjustable wrench, turn the on/off switch shaft counterclockwise 90 degrees to turn power off to the unit
8. Close door and secure the two door clamp screws

**Programmed Parameter Values**

n001	<b>0</b>	n028	<b>0</b>	n055	<b>2.0</b>	n082	<b>0</b>
n002	<b>3</b>	n029	<b>36</b>	n056	<b>0</b>	n083	<b>0.2</b>
n003	<b>230.0</b>	n030	<b>100</b>	n057	<b>0</b>	n084	<b>0</b>
n004	<b>0</b>	n031	<b>25</b>	n058	<b>0.0</b>	n085	<b>1.00</b>
n005	<b>0</b>	n032	<b>16.0</b>	n059	<b>0.0</b>	n086	<b>1.0</b>
n006	<b>1</b>	n033	<b>3</b>	n060	<b>1.0</b>	n087	<b>10.0</b>
n007	<b>1</b>	n034	<b>3</b>	n061	<b>1</b>	n088	<b>0.00</b>
n008	<b>0</b>	n035	<b>0</b>	n062	<b>0</b>	n089	<b>0</b>
n009	<b>1</b>	n036	<b>2</b>	n063	<b>0</b>	n090	<b>100</b>
n010	<b>F</b>	n037	<b>4</b>	n064	<b>30</b>	n091	<b>0.0</b>
n011	<b>400.0</b>	n038	<b>9</b>	n065	<b>1.0</b>	n092	<b>0</b>
n012	<b>400.0</b>	n039	<b>10</b>	n066	<b>0.0</b>	n093	<b>0</b>
n013	<b>400.0</b>	n040	<b>0</b>	n067	<b>0.0</b>	n094	<b>1.0</b>
n014	<b>300.0</b>	n041	<b>1</b>	n068	<b>0.434</b>	n095	<b>0</b>
n015	<b>1.5</b>	n042	<b>0</b>	n069	<b>172</b>	n096	<b>94.75</b>
n016	<b>10.0</b>	n043	<b>1</b>	n070	<b>1</b>	n097	<b>50</b>
n017	<b>1.5</b>	n044	<b>0</b>	n071	<b>170</b>	n098	<b>12</b>
n018	<b>10.0</b>	n045	<b>0</b>	n072	<b>160</b>	n099	<b>1</b>
n019	<b>3.5</b>	n046	<b>100</b>	n073	<b>0.0</b>	n100	<b>0</b>
n020	<b>7.0</b>	n047	<b>0</b>	n074	<b>4</b>	n101	<b>0.5</b>
n021	<b>10.0</b>	n048	<b>0</b>	n075	<b>160</b>	n102	<b>0.2</b>
n022	<b>10.0</b>	n049	<b>1.00</b>	n076	<b>1.0</b>	n103	<b>1</b>
n023	<b>1</b>	n050	<b>6</b>	n077	<b>0.0</b>	n104	<b>1</b>
n024	<b>20</b>	n051	<b>0</b>	n078	<b>0.0</b>	n105	<b>0</b>
n025	<b>360</b>	n052	<b>150</b>	n079	<b>0</b>	n106	<b>0</b>
n026	<b>0</b>	n053	<b>0.7</b>	n080	<b>7</b>	n107	<b>2</b>
n027	<b>0</b>	n054	<b>100</b>	n081	<b>8</b>	n108	<b>1</b>