

Gerber

Scientific Products

151 Batson Drive, Manchester, CT 06040
(860) 643-1515

Dear Gerber Sabre™ Customer:

Thank you for purchasing the Sabre, Gerber Scientific Products advanced, high-speed, three-dimensional router/engraver.

This Pre-Installation Checklist will assist you in preparing your site prior to the arrival of your Sabre. Please review this checklist carefully. The checklist includes:

- Physical specifications
- Handling instructions
- Aisle and doorway clearance information
- Operating environment
- Electrical requirements
- T-Vac™ Table Option requirements
- Air requirements
- Work area space requirements
- Handling transportation claims

Prepare your site according to the checklist. The factory-trained distributor installation technicians will arrive to install your Sabre.

THE SABRE SHOULD BE INSTALLED BY FACTORY-TRAINED PERSONNEL ONLY.

If you have questions regarding the Pre-Installation Checklist, please contact the Gerber Router Support Group at:



860-528-1028
860-290-5568 (fax)

We welcome your comments about the system's operation, the quality it adds to your products, and the support you receive from your distributor.

Sincerely,

Kenneth Hooks
Router Customer Support Supervisor

Enclosures

- Pre-Installation Checklist
- T-Vac Table Option Fact Sheet

Gerber Scientific Products, Inc.

Sabre™ Series Router

Pre-Installation

Checklist



Sabre™ Series Pre-Installation Checklist

Physical specifications

The system and all options (except for the Automatic Tool Changer) are usually shipped in one crate. Below are the physical specifications of the crated and assembled system.

Crated Sabre Systems

	Length	Width	Height	Weight
Sabre 404 (without options)	81 inches (2057.4 mm)	75 inches (1905 mm)	73 inches (1854.2 mm)	1760 lb. (798.3 kg)
Sabre 408 (without options)	130 inches (3302 mm)	75 inches (1905 mm)	73 inches (1854.2 mm)	2530 lb. (1147.6 kg)

Assembled Sabre Systems

	Length	Width	Height	Weight
Sabre 404 Table	75 inches (1905 mm)	68 inches (1727.2mm)	60 inches (1524 mm)	1245 lb. (564.7 kg)
Sabre 408 Table	123 inches (3124 mm)	68 inches (1727.2 mm)	60 inches (1524 mm)	1575 lb. (714.4 kg)
Electrical Cabinet	25 inches (635 mm)	18 inches (457.2 mm)	29 inches (736.6 mm)	175 lb. (79.4 kg)

If you purchased the Automatic Tool Changer (ATC) option, it is shipped in six boxes strapped to a standard shipping palette.

Handling instructions

Gerber Scientific Products will ship the Sabre FOB Manchester, CT. Common Carrier service may be provided directly to the installation site. The Sabre is a precision machine tool and should be handled accordingly. Never lift the system higher than absolutely necessary or transport it in an abusive manner.

Either you or your distributor must make provisions for unloading the Sabre from the truck and moving it to its destination. A crated Sabre system requires a forklift, or pallet jack with extended forks of 75

inches (1.9 m) is required if your facility does not have loading dock access. The uncrated Sabre requires a forklift, or pallet jack with forks a minimum of 68 inches (1.73 m) in length to safely move the system.

☑ Aisle and doorway clearance information

Refer to the crated dimensions of the packaged Sabre system to ensure there is sufficient clearance for cornering the package. If your maximum clearance is less than the crated dimensions, please contact the Gerber Router Support Group for special instructions.

☑ Operating environment

The operating environment must be within a temperature range of 55°F - 95°F (13°C - 35°C), and within a relative humidity range of 0% - 70%.

☑ Electrical requirements

There are different electrical requirements depending on the motor or spindle you ordered with your Sabre. Please refer to the following three subsections to determine the specific electrical requirements

Sabre

The Sabre requires an input voltage of 187 VAC – 264 VAC, single phase, 50/60 Hz. Determine the line voltage prior to installation. The receptacle must be near the Sabre, and must be easily accessible. It must be wired by a licensed industrial electrician prior to installation. If there is no wall within six feet of the unit, a ceiling drop should be provided. The system is equipped with a 12-foot power cord.

Note: The Sabre reaches its maximum positioning rate at nominal line voltage of 230 VAC.

The electrical outlet receptacle (which you provide) must be installed prior to the installation of the Sabre. **You MUST use the receptacle specified at the right.** DO NOT substitute another receptacle in its place. **Do not tie G and W together. The export (international) configuration does not use the W connection.** Contact your distributor if you are unsure of the configuration he ordered for you.

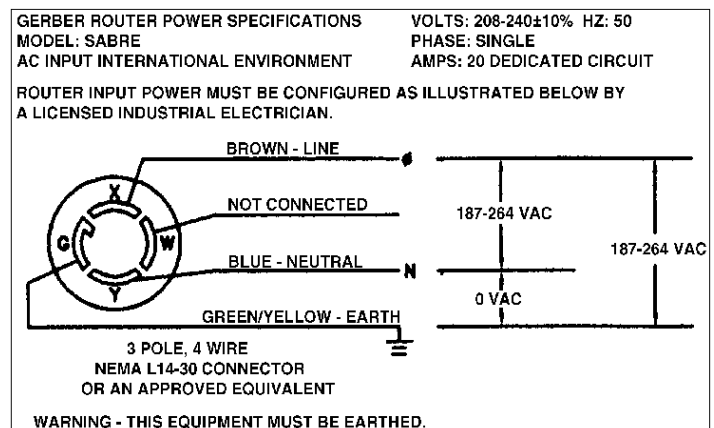
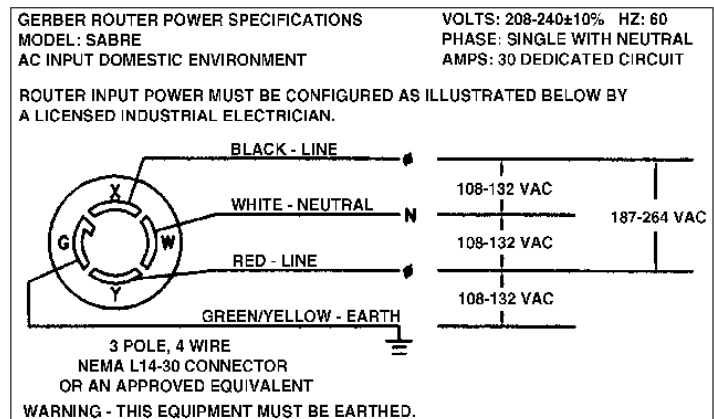

Perske spindle option

If you purchased the Perske High Frequency Spindle Option, it requires its own dedicated electrical circuit in addition to the circuit used by the Sabre. It must be wired by a licensed industrial electrician prior to installation. The controller is equipped with a 9-foot power line cord to plug into the outlet receptacle.

The electrical outlet receptacle must be installed prior to the installation of the Sabre. **You MUST use the specified receptacle shown at the right.** DO NOT substitute another receptacle in its place.

Note: The top schematic is for the three phase, 200-230 V controller. The middle schematic is for the three phase, 380-460 V controller. The bottom schematic is for the three phase, 380-460 V CE approved controller. The schematic at the top of the next page is for the single phase, 200-230 V CE approved controller.

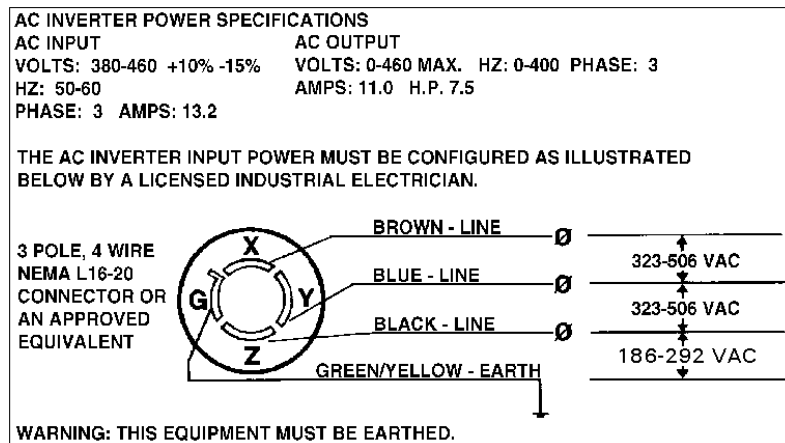
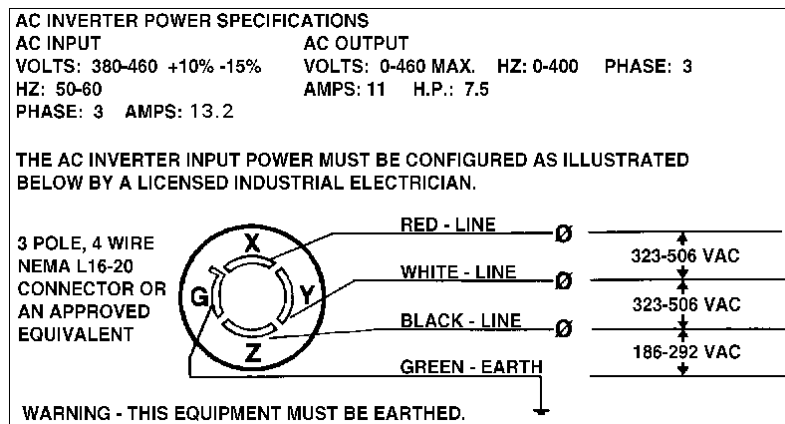
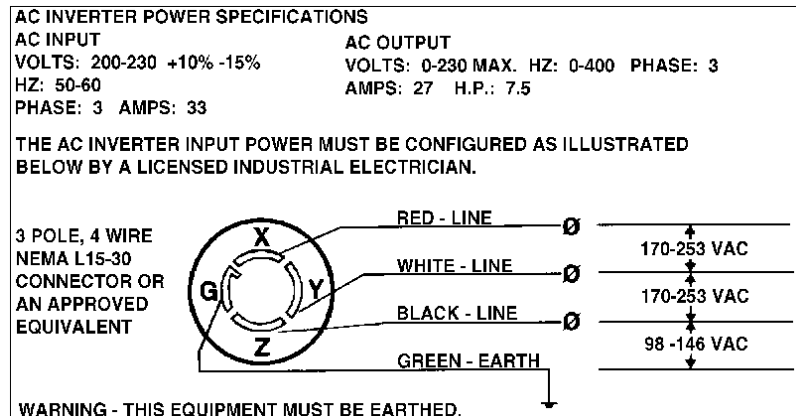

AC INVERTER POWER SPECIFICATIONS
AC INPUT VOLTS: 200-230 +10% -15% HZ: 50-60 PHASE: SINGLE AMPS 17
AC OUTPUT VOLTS: 0-230 MAX. HZ 0-400 PHASE: 3

THE AC INVERTER INPUT POWER MUST BE CONFIGURED AS ILLUSTRATED BELOW BY A LICENSED INDUSTRIAL ELECTRICIAN.

3 POLE, 4 WIRE NEMA L14-20 CONNECTOR OR AN APPROVED EQUIVALENT

BROWN
NOT CONNECTED
BLUE
GREEN/YELLOW - EARTH

170 -253 VAC

WARNING - THIS EQUIPMENT MUST BE EARTHED.

Colombo ATC spindle option

If you purchased the ATC option with the Colombo High Frequency Spindle, it requires its own dedicated electrical circuit in addition to the circuit used by the Sabre. It must be wired by a licensed industrial electrician prior to installation. The controller is equipped with a 11-foot power line cord to plug into the outlet receptacle.

The electrical outlet receptacle must be installed prior to the installation of the Sabre. **You MUST use the specified receptacle shown at the right.** DO NOT substitute another receptacle in its place.

Note: The top schematic is for the three phase, 200-230 V controller used on domestic routers. The bottom schematic is for the three phase, 380-460 V controller used on international routers.

AC INVERTER POWER SPECIFICATIONS
AC INPUT VOLTS: 200-230 +10% -15% HZ: 50-60 PHASE: 3 AMPS: 36
AC OUTPUT VOLTS: 0-230 MAX. HZ: 0-400 PHASE: 3 AMPS: 28.5 H.P. 10

THE AC INVERTER INPUT POWER MUST BE CONFIGURED AS ILLUSTRATED BELOW BY A LICENSED INDUSTRIAL ELECTRICIAN.

3 POLE, 4 WIRE NEMA L15-50 CONNECTOR OR AN APPROVED EQUIVALENT

GREEN - EARTH
BLACK - LINE
RED - LINE
WHITE - LINE

98 -146 VAC
170-253 VAC
170-253 VAC

WARNING - THIS EQUIPMENT MUST BE EARTHED.

AC INVERTER POWER SPECIFICATIONS
AC INPUT VOLTS: 380-460 +10% -15% HZ: 50-60 PHASE: 3 AMPS: 22
AC OUTPUT VOLTS: 0-380 MAX. HZ: 0-400 PHASE: 3 AMPS: 17.5 H.P. 10

THE AC INVERTER INPUT POWER MUST BE CONFIGURED AS ILLUSTRATED BELOW BY A LICENSED INDUSTRIAL ELECTRICIAN.

3 POLE, 4 WIRE NEMA L16-30 CONNECTOR OR AN APPROVED EQUIVALENT

BROWN - LINE
BLUE - LINE
BLACK - LINE
GREEN/YELLOW - EARTH

323-506 VAC
323-506 VAC
186-292 VAC

WARNING - THIS EQUIPMENT MUST BE EARTHED.

Chip Removal System electrical requirements

The domestic model Chip Removal System requires a vacuum with a minimum 3 HP motor using 115 V at 15 Amp maximum. The export model Chip Removal System requires a vacuum with a minimum 3 HP motor using 230 v 7.5 Amp maximum.

The vacuum hose must be 2.5 inch (6.35 cm) diameter to attach to the Chip Removal System. The Chip Removal System vacuum plugs into the outlet on the back of the Electrical cabinet.

T-Vac™ Table Option requirements

This section provides ordering information and pre-installation instructions for the T-Vac Table Option equipment.

Equipment ordering information

The T-Vac Table Option requires that you purchase and have on site the vacuum filter, relief valve, vacuum pump, and vacuum pump motor control panel prior to installing the Sabre. The part numbers of the equipment you need is provided in the enclosed T-Vac Table Option Fact Sheet.

Gerber has made arrangements with the supplier, Siemens® Energy & Automation, Inc., to purchase this equipment at a substantially discounted price. To order it, contact:

Mr. Vijay Kumar
Siemens Energy & Automation, Inc.
Phone: 201-569-1173
Fax: 201-569-1696

Note: When ordering, it is important to mention that your order is for a Gerber routing system. This qualifies you for the discounted price.

Please order this equipment immediately. It must be at your site before the Sabre is installed. The distributor installation technician will position the equipment when he arrives. You will need to have a licensed industrial electrician make the final connections from the motor through the control panel to the circuit breaker after the equipment is in position.

Vacuum blower motor pre-installation instructions

The power requirements for the Siemens vacuum blower motor are:

- 10 HP, three phase, 400 - 480 V at 11.5 Amp, or
- 10 HP, three phase, 200 - 240 V at 23 Amp, or
- 7 HP, single phase, 208 - 230 V at 39 - 37 Amp.

The vacuum pump motor is supplied with a pre wired control panel. The control panel consists of an on/off switch, a magnetic starter, and a thermal overload heater element. Have the licensed industrial electrician run the wires from the circuit breaker to the control panel so that the control panel will be close to the front of the Sabre system as shown in the work area illustration. Do not wire the vacuum blower to the control panel until after the installation technician positions the blower motor.

If you have any questions regarding the equipment or instructions, please contact Mr. Vijay Kumar at Siemens. If you have questions regarding the control panel or its placement, please contact Gerber Router Support Group at:



860-528-1028
860-290-5568 (fax)

Note: When ordering the control panel, please specify to Siemens your facility voltage to ensure that the control panel/starter is equipped with the correct magnetic coil.

Air requirements

The Mist Coolant System requires approximately 0.5 CFI of compressed air at 100 - 120 pounds per square inch, which can be provided by a 0.25 to 0.5 horsepower compressor.

The ATC requires clean and dry compressed air of at least 100 psi minimum at 10 cfm. The purpose of the compressed air is to:

- control the tool changer movements
- operate safety system mechanisms in the tool changer
- cool the Colombo spindle
- operate the spindle's tool holder grab and release mechanism
- operate safety system mechanisms in the spindle

Note: To meet the compressed air requirements, we suggest a heavy-duty 5 hp compressor motor with a large tank (approximately 80 gallons).

CAUTION: Do not install or run the Colombo spindle unless you have a compressed air supply of at least 100 psi minimum at 10 cfm. This air supply is in addition to any other air requirements that you have and should be provided on a stand-alone line. If the air pressure drops or is interrupted, the spindle will immediately shut down. It is a good idea to install a dryer in the air line, especially in humid environments. You also must have a filter in the air line to remove any oil blow-by from the compressor.

The clean and dry compressed air is critical to the safe and efficient operation of the spindle and tool changer. A 5 micron filter/regulator is mounted on the right rear leg of the Sabre to assist in maintaining air quality, but the key to reliable operation is to have a carefully controlled and maintained air source.

Work area space requirements

Both the Sabre 404 and 408 require a work area width of 15.6 ft (4.8 m). This provides about 5 ft (1.5 m) of space on either side of the router for safe access to the table and controls. If you have the ATC option, you should allow an additional 3 ft (1 m) width to accommodate the ATC footprint.

The Sabre 404 requires a work area length of 17.75 ft (5.4 m). This provides about 7 ft (2.1 m) in front of the router and 3 ft (.9 m) behind the Electrical Cabinet for safe access and cutting large panel jobs.

The Sabre 408 requires a work area length of 21.75 ft (6.6 m). This provides about 7 ft (2.1 m) in front of the router and 3 ft (.9 m) behind the Electrical Cabinet for safe access and cutting large panel jobs.

Plan extra room for storing materials and supplies, and if you intend on doing long pull through jobs. Locate the power receptacles and air supply to the right of the Sabre. Run the wires to the optional vacuum blower motor control panel so that it can be placed near the keyboard at the front of the system.

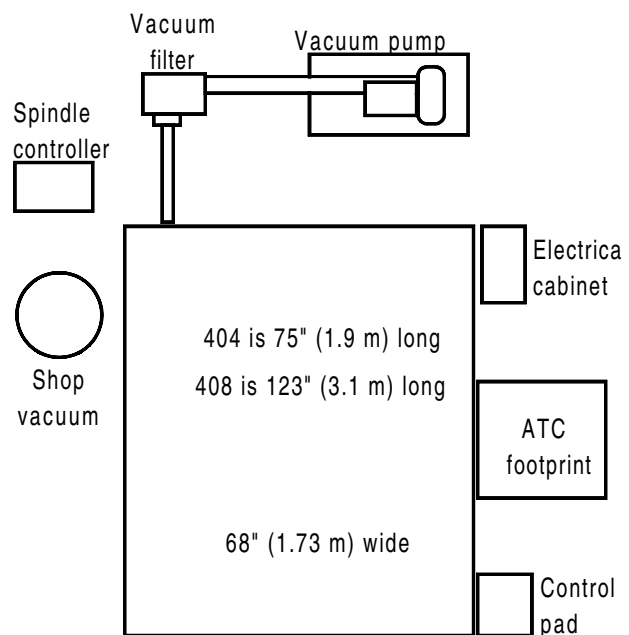

Handling transportation claims

Gerber Scientific Products also offers the following guidelines for handling transportation claims. Since your Sabre is shipped FOB Manchester, CT, you, the customer, are responsible for any occurrences relating to the system after it leaves our dock. The following guidelines will assist you with identifying possible damage and the procedures to follow to file a claim. Three primary transportation claims are **loss, visible damage, and concealed damage.**

Loss

A carrier's driver will have a delivery receipt itemizing the contents of the shipment. You and the driver should physically count the items as they are delivered and verify them with the delivery receipt. If the shipment is not complete, make a loss notation on **ALL** copies of the delivery receipt, which you and the driver should sign.

Clearly and concisely note the shortage on the delivery receipt and the customer copy. Describe **EXACTLY** what is missing; do not just write "one piece short."

Visible Damage

When the carrier delivers your shipment, you must examine **EACH** container as it is delivered. If any container shows evidence of damage, open the package **IMMEDIATELY**. You and the driver should make the inspection together. List and describe the damage on the delivery receipt and have it co-signed by the driver. Again, describe the visible damage in as much detail as possible, not just in general terms.

Concealed Damage

This is the most difficult type of claim to collect from the carrier. The burden of proof reverts to you, the customer, to prove the shipment suffered the damage or loss while in the carrier's possession. The carrier holds a clear delivery receipt with no notation describing damage or loss. The longer the shipment is in your possession, the more difficult it is to collect from the carrier. Time is of the utmost importance.

When your distributor uncrates the Sabre system, inspect everything for damage or loss. As soon as you discover concealed damage or loss, telephone the carrier **IMMEDIATELY** and request an inspection. Be sure to ask the name of the person you talk to, and write it down. **IMMEDIATELY** confirm your telephone conversation with a letter directed to that person.

If you discover damage (as opposed to loss), stop unpacking and do nothing further to disturb the shipment. Save all packaging and leave the damaged equipment exactly where it is, if at all possible.

The carrier or its agent will make the inspection within five working days after you, the customer, report the concealed damage or loss. If the carrier does not make the inspection or waives inspection, you should make the inspection and record all information to the best of your ability. All reports of concealed loss or damage must be received by the carrier within fifteen working days.

Copyright © 1998 Gerber Scientific Products, Inc.

Sabre and T-Vac are trademarks of Gerber Scientific Products, Inc. Siemens is a registered trademark of Siemens Energy & Automation, Inc.